

An improved Technique to Track Maximum Power Point for PV Cell

Satish Kumar Jangid¹, Vikash Kumar Saini² and Shailendra Sharma³

¹Research Scholar, Rajeev Gandhi Technical University

²Research Scholar, MNIT Jaipur

²MIT Mandsaur

E-mail: ¹satishjangid90@gmail.com, ²vikashsaini75@yahoo.com,

³shailendra.sharma@mitmandsaur.info

Abstract—This paper presents a new approach of tracking the maximum power point for photovoltaic array. The fuzzy logic controller examines the output PV power at each sample time (k), and determines the change in power relative to voltage (dP/dV). The duty cycle of the PWM is varied according to dP/dV to drive the buck converter to operate the PV module at MPP. Fuzzy logic controller leads to an improved time response. The major difference between the proposed algorithm and other techniques is that the proposed algorithm is used to control directly the power drawn from the PV. The proposed MPPT has several advantages: simplicity, high convergence speed, and independent on PV array characteristics. The algorithm is tested under various operating conditions. The obtained results have proven that the MPP is tracked even under sudden change of irradiation level.

Keywords: Photovoltaic system, MPPT, P&O, Fuzzy Logic Control

1. INTRODUCTION

With the limitation of the fossil fuels becoming more apparent, solar energy is emerging as the renewable energy source that could change the future. Solar energy using photovoltaics (PV) does not harm the environment with greenhouse gas emission and also it is abundantly available, clean, no noise and free. The conversion efficiency of electric power generation is 46% as reported in Fraunhofer Institute for Solar Energy Systems, ISE, Germany in 2014. A PV Array under constant irradiance has a current voltage characteristics like that shown in fig.1. There is a unique point on the curve called maximum power point (MPP), at which the array operates with maximum efficiency and produce maximum output power. When the PV array is directly connected to the load (a so called directly connected system), the system operating point will be at the intersection of the I-V curve of the PV array and the load line as shown in fig. 1.

This operating point is not at the PV array MPP. Thus in a directly coupled system, the PV array must usually be oversized to ensure that the load's power requirement can be supplied. This leads to an overly expensive system. To overcome this problem a switch mode power converter called

as **Maximum Power Point Tracker**, can be used to maintain the PV array operating point at MPP.

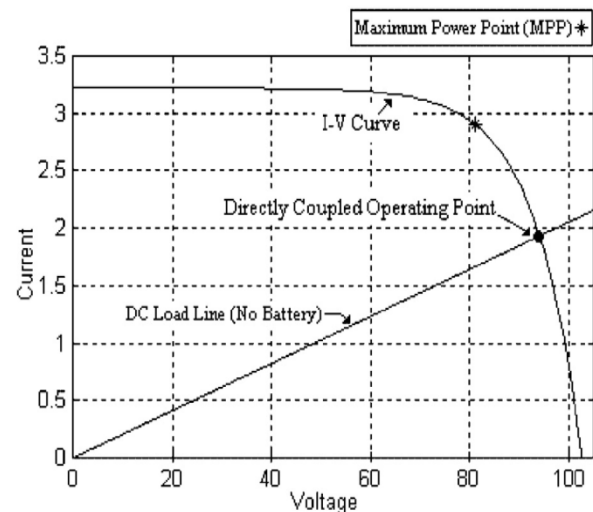

Fig. 1: I-V curve and the load line

Thus in a directly coupled system, the PV array must usually be oversized to ensure that the load's power requirement can be supplied. This leads to an overly expensive system.

To overcome this problem a switch mode power converter called as **Maximum Power Point Tracker**, can be used to maintain the PV array operating point at MPP.

2. MAXIMUM POWER POINT TRACKING (MPPT)

MPPT is a fully electronic system (not to be confused with the mechanical tracking system), that varies the electrical operating point of the modules so that the modules are able to deliver maximum available power. There are many MPPT techniques found in the literature: Perturb and Observe (P&O), Incremental Conductance, Fuzzy Logics, Artificial Neural

Network. The methods varying complexity, sensors required, sensed parameters, range of effectiveness, implementation hardware, convergence speed, cost, and popularity. The proposed algorithm presents a simple MPPT scheme that does not require special measurement of open circuit voltage or short circuit current.

A new fuzzy logic rules for photovoltaic array is proposed. The algorithm detects the maximum power point of the PV. Fuzzy logic controller with PWM is used to control the operation of buck chopper such that PV module always operates at its maximum power computed from fuzzy logic rules. The heart of the modification implemented in the paper is to improve the time response of tracking of maximum power point.

3. PV MODELLING

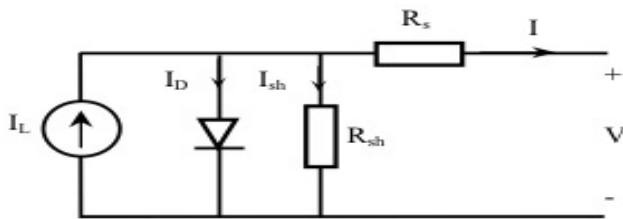

Fig. 2: Equivalent circuit of PV module

The simple model of PV consists of a current source, a diode, and a resistor as shown in fig. 2. Output current of the photocell (I_L) is directly proportional to the irradiation level of the light falls on the solar cell.

The I-V characteristic of PV is expressed by the following equation:

$$I = I_L - I_0 \left(e^{\frac{q(V+IR_s)}{kT}} - 1 \right) - \frac{V+IR_s}{R_{sh}} \dots\dots\dots .1$$

Where:

- I is the cell current (A).
- I_L is the light generated current (A).
- I₀ is the diode saturation current.
- q is the charge of electron = 1.6x10⁻¹⁹ (C).
- K is the Boltzmann constant (j/K).
- T is the cell temperature (K).
- R_s, R_{sh} are cell series and shunt resistance (ohms).
- V is the cell output voltage (V).

Fig. 3 and 4 show the I-V and P-V characteristics of the PV module, respectively. The electrical characteristic of PV module considered in the experiment is described in Table 1.

Table 1: Electrical characteristics of PV Module

Variable	Level
Maximum power, P _{max}	50 W
Voltage @ maximum power, V _{max}	17.3 V
Current @ maximum power, I _{max}	2.89 A
Short circuit current, I _{sc}	3.17 A
Open circuit voltage, V _{oc}	21.8 V

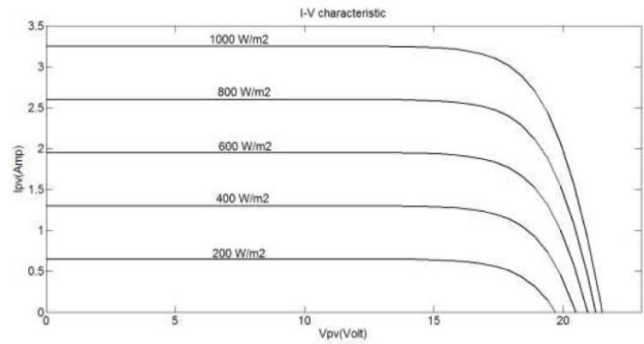

Fig. 3: I-V Characteristics of PV module

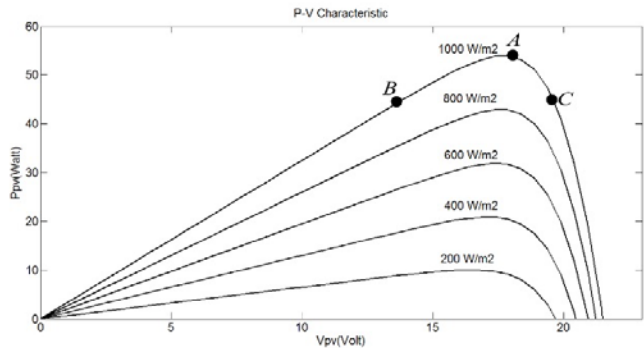

Fig. 4: P-V Characteristics of PV module

Observing Fig. 4, for a particular solar irradiation level, the point A is the maximum power point (MPP). At this point, it yields an equation

$$\frac{dP}{dV} = 0.$$

When the operation point changes to B or C, the equations are expressed in Eqs. (3) and (4) respectively.

$$\frac{dP}{dV} > 0$$

$$\frac{dP}{dV} < 0$$

The objective of MPPT technique is to track the operation point to the maximum one (pt. A)

4. COMMONLY USED MPPT TECHNIQUES

The problem considered by MPPT methods is to automatically find the voltage V_{MPP} or current I_{MPP} at which a PV array delivers maximum power under a given temperature and irradiance. In this section, commonly used MPPT methods are introduced in an arbitrary order.

A. Fractional Open-Circuit Voltage

The method is based on the observation that, the ratio between array voltage at maximum power V_{MPP} to its open circuit voltage V_{OC} is nearly constant.

$$V_{MPP} \approx k_1 V_{OC}$$

This factor k_1 has been reported to be between 0.71 and 0.78. Once the constant k_1 is known, V_{MPP} is computed by measuring V_{OC} periodically. Although the implementation of this method is simple and cheap, its tracking efficiency is relatively low due to the utilisation of inaccurate values of the constant k_1 in the computation of V_{MPP} .

B. Fractional Short-Circuit Current

The method results from the fact that, the current at maximum power point I_{MPP} is approximately linearly related to the short circuit current I_{SC} of the PV array.

$$I_{MPP} \approx k_2 I_{SC}$$

Like in the fractional voltage method, k_2 is not constant. It is found to be between 0.78 and 0.92. The accuracy of the method and tracking efficiency depends on the accuracy of k_2 and periodic measurement of short circuit current.

C. Perturb and Observe

In P&O method, the MPPT algorithm is based on the calculation of the PV output power and the power change by sampling both the PV current and voltage. The tracker operates by periodically incrementing or decrementing the solar array voltage. If a given perturbation leads to an increase (decrease) in the output power of the PV, then the subsequent perturbation is generated in the same (opposite) direction. So, the duty cycle of the dc chopper is changed and the process is repeated until the maximum power point has been reached. Actually, the system oscillates about the MPP. Reducing the perturbation step size can minimise the oscillation. However, small step size slows down the MPPT. To solve this problem, a variable perturbation size that gets smaller towards the MPP.

D. Incremental Conductance

The method is based on the principle that the slope of the PV array power curve is zero at the maximum power point. $(DP/dV) = 0$. Since $(P = VI)$, it yields:

$$\Delta I/\Delta V = -I/V, \text{ at MPP}$$

$$\Delta I/\Delta V > -I/V, \text{ left of MPP}$$

$$\Delta I/\Delta V < -I/V, \text{ right of MPP}$$

The MPP can be tracked by comparing the instantaneous conductance (I/V) to the incremental conductance $(\Delta I/\Delta V)$.

The algorithm increments or decrements the array reference voltage until the condition at MPP is satisfied. Once the Maximum power is reached, the operation of the PV array is maintained at this point. This method requires high sampling rates and fast calculations of the power slope.

5. PROPOSED MPPT METHOD

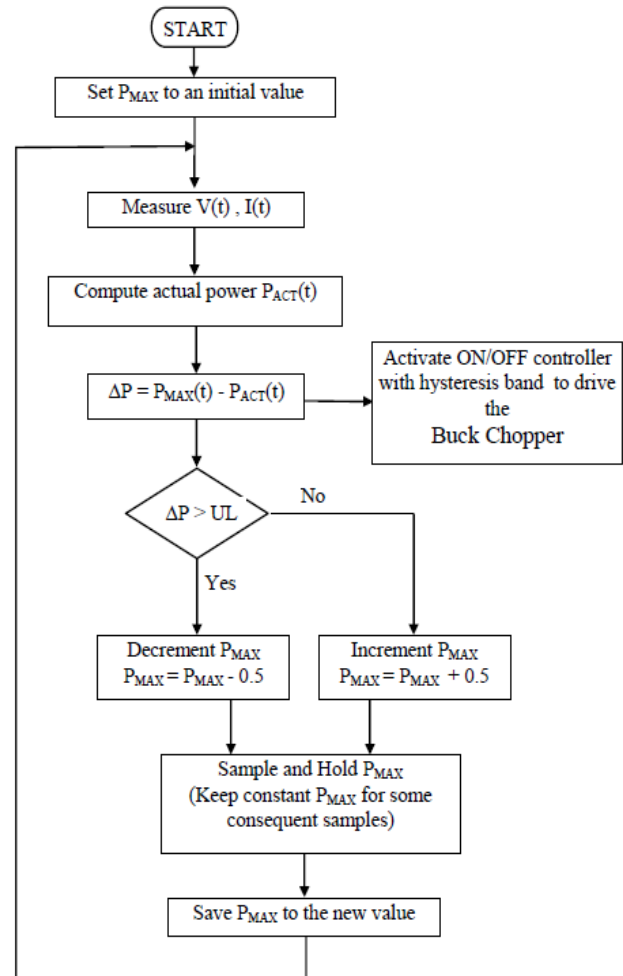

Fig. 5: Flow Chart of the P&O Technique

The MPPT techniques found in literatures concentrates on tracking either V_{MPP} or I_{MPP} but the proposed algorithm engrossed the essence of tracking the maximum possible power, P_{max} , that can be extracted from PV.

The proposed concept was examined by two methods:

1) Perturb and observe

This method tracks directly the maximum possible power P_{Max} that can be extracted from the PV. Increase gradually the computed value of P_{Max} and controls the power extracted from the PV to this value. If the actual power is well controlled within the tolerance band of the hysteresis controller, the partial tracking is succeeded and P_{Max} can be increased to

greater value. But, if the power controller fails to track the P_{Max} , this means that the computed P_{Max} is greater than the maximum possible power of the PV. Therefore, a reduction (decreasing) in the computed P_{max} must be done until the error between P_{Max} and P_{actual} is limited between upper and lower limit.

2) Fuzzy Logic

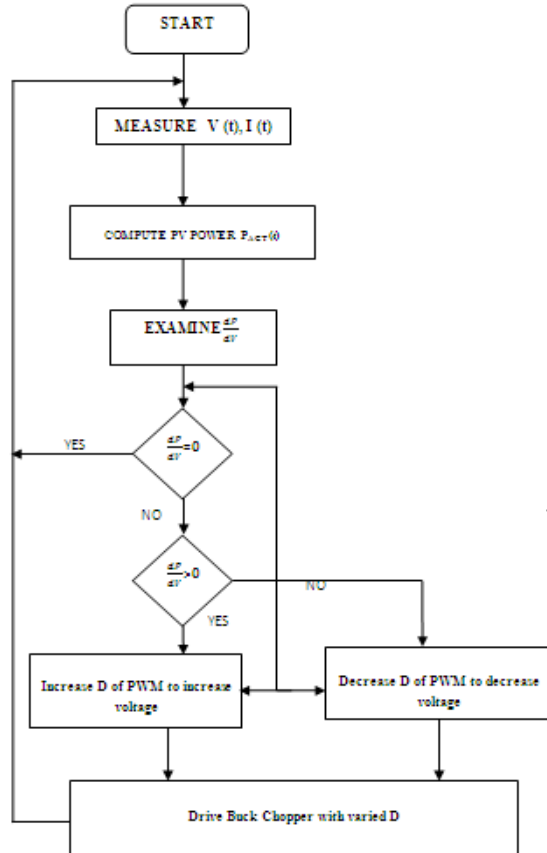

Fig. 6: Flow Chart of the Improved Technique

The Fuzzy logic controller examines the output PV power at each sample time (k), and determines the change in power relative to voltage (dp/dv). If this value is greater than zero the controller change the duty cycle of the pulse width modulation (PWM) to increase the voltage until the power is maximum or the value (dp/dv) =0, if this value less than zero the controller changes the duty cycle of the PWM to decrease the voltage until the power is maximum.

The simulation output of the both methods leads to the result that with Fuzzy Logic method the time response was improved in comparison with Perturb and Observe time response.

6. SYSTEM MODELLING

The block diagram of the PV system for both the methods under investigation is shown in fig. 7 and fig. 8. The PV power system is modelled using Power System block set under

MATLAB. The MPPT algorithm is modelled using Simulink blocks.

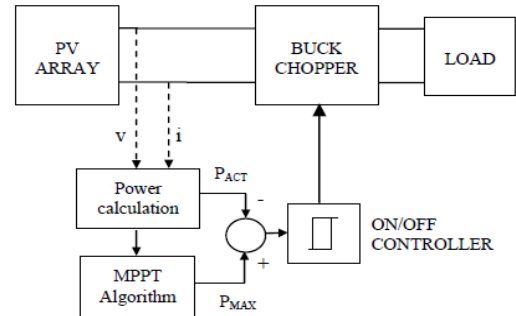

Fig. 7: Block Diagram of the P&O Technique

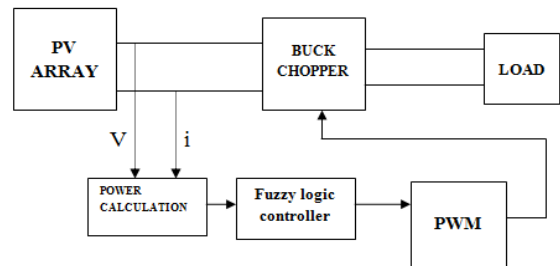

Fig. 8: Block Diagram of the Improved Technique

7. SIMULATION RESULT

With the proposed approach, computed P_{max} is 51.5 W, while the theoretical value was 54 W. So the tracking efficiency is 95 %. Also upon comparing the simulation result of both the approaches of proposed design, it was remarked that the time response was improved for fuzzy logic based technique over Perturb and Observe technique. The result is as shown below:

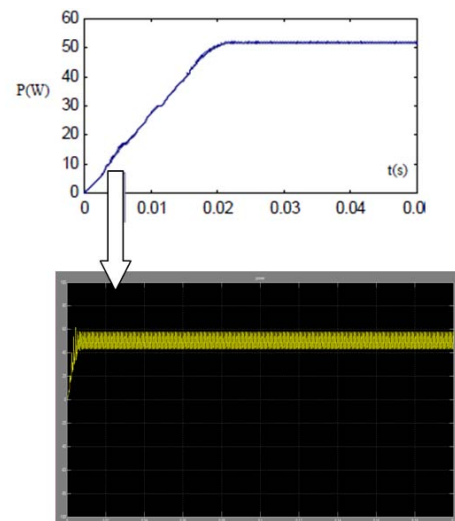

Fig. 9: Tracked maximum power and Extracted PV power before and after improvement

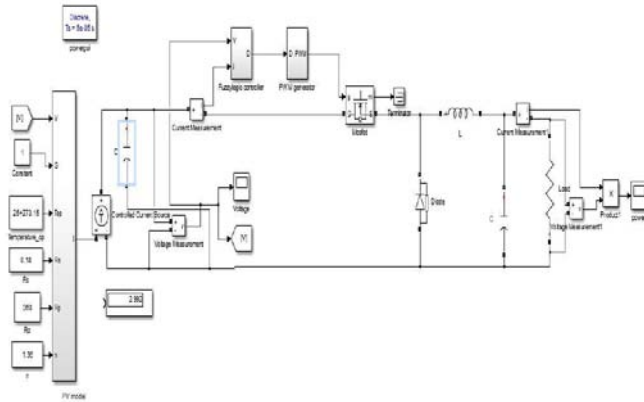

Fig. 10: Overall Simulation circuit

As clear from the result, in Perturb and observe, steady state is achieved at 0.02 sec, whereas in fuzzy logic controller the steady state is achieved at 0.01 sec.

8. CONCLUSION

The paper proposes a simple MPPT method that requires only measurements of PV voltage and current with the need to any environmental measurements (temperature, irradiance). The proposal was compared on two platforms to have better response and the result is achieved by computing a better time response with the fuzzy logic controller over modified Perturb and observe. The proposed method offers different advantages which are: good tracking efficiency, relatively high convergence speed and well control for the extracted power.

REFERENCES

- [1] N. Femia, *et. Al.* "Optimization of Perturb and observe Maximum Power Point tracking Method," *IEEE Trans. Power Electron.*, Vol. 20, pp. 963-973, July 2005.
- [2] E. Koutroulis; *et. al.* "Development of a Microcontroller-based Photovoltaic maximum power tracking control system", *IEEE Trans. On power Electron.*, Vol. 16, No. 1, pp. 46-54, 2001.
- [3] J.A.Jiang *et. Al.* , "Maximum Power Tracking for Photovoltaic Power Systems," *Tamkang Journal of Science and Engineering*, Vol. 8, No. 2, pp. 147-153, 2005..
- [4] S. Jain and V. Agarwal, "A New Algorithm for Rapid Tracking of Approximate Maximum Power Point in Photovoltaic Systems," *IEEE Power Electronic Letter.*, Vol. 2, pp. 16-19, Mar. 2004.
- [5] W. Xiao and W. G. Dunford, "A modified adaptive hill climbing MPPT method for photovoltaic power systems," *35th. Annual IEEE Power Electron. Specialists Conf.*, pp. 1957-1963, 2004.
- [6] Y. Kuo, *et. Al.*, "Maximum power point tracking controller for photovoltaic energy conversion system," *IEEE Trans. Ind. Electron.*, Vol. 48, pp. 594-601, 2001.
- [7] Won C.-Y., Kim D.-H., Kim S.-C., Kim W.-S., Kim H.-S., "A new maximum power point tracker of photovoltaic arrays using fuzzy controller". In Proc: 25th Annual IEEE PESC, 20– 25 Jun. 1994, vol. 1, pp. 396–403.
- [8] Simoes M.G., Franceschettin N.N.: "Fuzzy optimization based control of a solar array", In Proc. IEE Electr. Power Appl., 1999, 146, (5), pp. 552–558.
- [9] "Modeling of fuzzy logic controller for variable step MPPT in photovoltaic system", *IJRET: International Journal of Research in Engineering and Technology* eISSN: 2319-1163 pISSN: 2321-7308
- [10] "Maximum power point tracking using a fuzzy logic control scheme", M.S. Ait Cheikh*, C. Larbes†, G.F. Tchoketch Kebir and A. Zerguerras , *Revue des Energies Renouvelables* Vol. 10 N°3 (2007) 387 – 395